

## Description of the Reactor Core of the Third Qinshan Nuclear Power Plant (TQNPP)

by

**Qiu Suizheng\* and Norman C. Johnston\*\***

\*Xi'an Jiaotong University

\*\*Atomic Energy of Canada Limited

### 1. General Description of The Reactor Core

The CANDU 6 reactor assembly is comprised of a horizontal cylindrical tank known as the calandria, 380 horizontal fuel channels aligned with the axis of the calandria and both vertical and horizontal reactivity control mechanisms oriented perpendicular to the axes of the calandria and fuel channels. This entire assembly is supported at the end shields by the end walls of the calandria vault

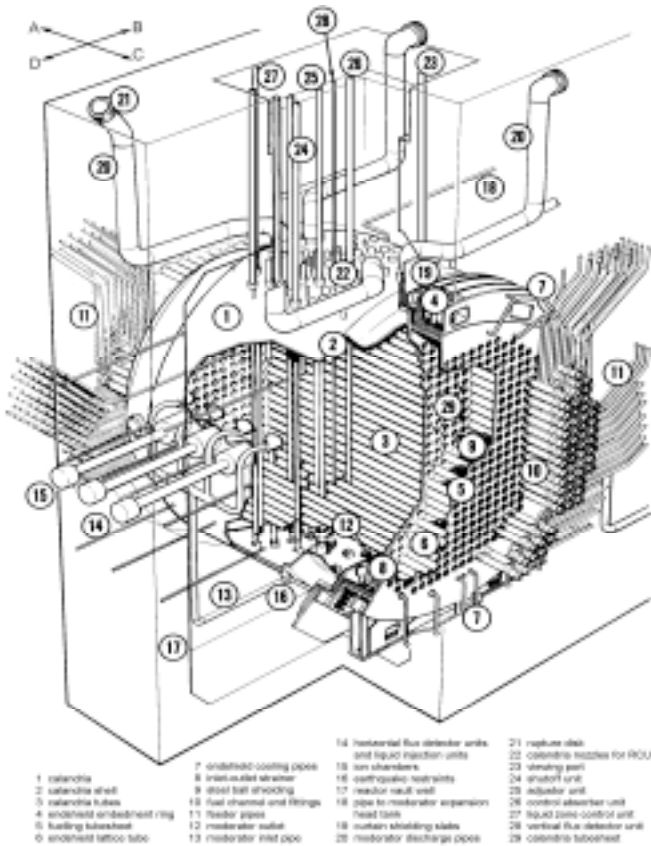

### 2. Calandria and Calandria Vault

The calandria is closed and supported at each end by end shields. Each end shield comprises an inner and an outer tubesheet joined together by 380 lattice tubes at each fuel channel location and a peripheral shell. The lattice tubes are arranged on a square pitch of about 28.6 cm and the end shields as

a whole support the calandria and fuel channels. The inner space of each end shield is filled with steel balls and light water to provide personnel shielding. The end shields are light water cooled as part of the vault cooling system. The calandria is filled with heavy water moderator at low temperature and pressure. The heavy water moderator enters the calandria through two sets of fan shaped nozzles on opposite sides of the main shell of the vessel and exits through two nozzles at the bottom of the calandria. The calandria is located in a light water filled, steel lined, concrete vault which provides thermal shielding.

Though part of the Class 3 moderator system, the calandria is optionally manufactured to the requirements of the ASME Boiler and Pressure Vessel Code, Section III, “Rules for

Construction of Nuclear Power Plant Components”, Subsection NC, “Rules for Class 2 Components”. It is fabricated from stainless steel and has a main shell diameter of 7.65 m, an inside core length of 5.94 m and a shell thickness of 28.6 mm.

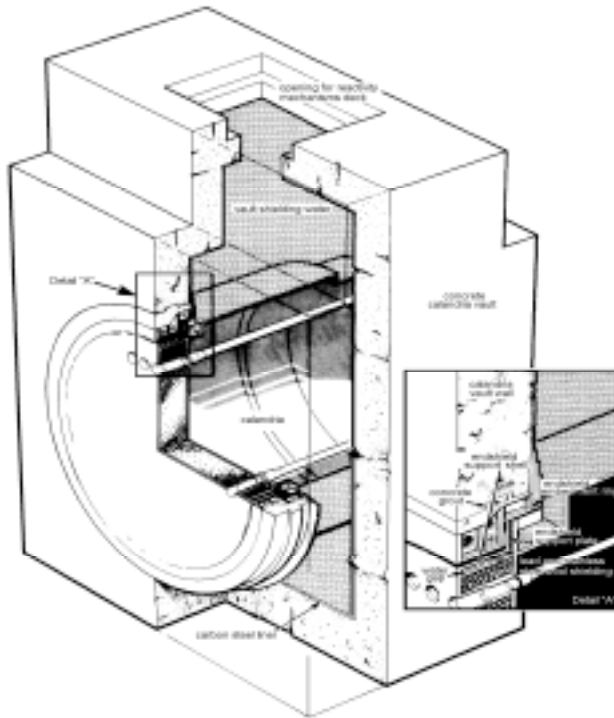

The calandria vault comprises a rectangular reinforced concrete structure, closed at the top by the reactivity mechanism deck. The reactivity mechanism deck supports the upper ends of the reactivity control units, their mechanisms, shielding, and connecting tubes and cables. The reactivity mechanism deck is a concrete-filled steel box structure with penetrations for the

reactivity control units.

## Fuel Channels

There are 380 fuel channels that comprise the in-core part of the primary heat transport system. Each fuel channel locates and supports 12 fuel bundles in the reactor core. They allow the primary heat transport fluid to pass through, removing the heat generated in the fuel and permit the fuelling machines to refuel while the reactor is operating at full power. The fuel channel assembly includes a zirconium niobium alloy pressure tube, a zirconium alloy calandria tube, stainless steel end fittings at each end, and four spacers which maintain separation of the pressure tube and the calandria tube. Each pressure tube is thermally insulated from the cool, low pressure moderator, by the CO<sub>2</sub> filled gas annulus formed between the outside of the pressure tube and the inside of the concentric calandria tube. The zirconium alloy calandria tube is joined at each end to one of the stainless steel calandria end shields by means of a sandwich type mechanical rolled joint. The calandria tube is an integral part of the calandria vessel pressure boundary.

Each end fitting incorporates a feeder connection through which heavy water coolant enters and leaves the fuel channel. Pressurized heavy water coolant flows around and through the fuel bundles in the fuel channel and removes the heat generated in the fuel by

nuclear fission. Coolant flow through adjacent channels in the reactor is in opposite directions. During on-power refuelling, the fuelling machines first make a leak tight connection to both ends of a channel, then gains access by removing the closure plugs and shield plugs from both end fittings of the channel to be refuelled.

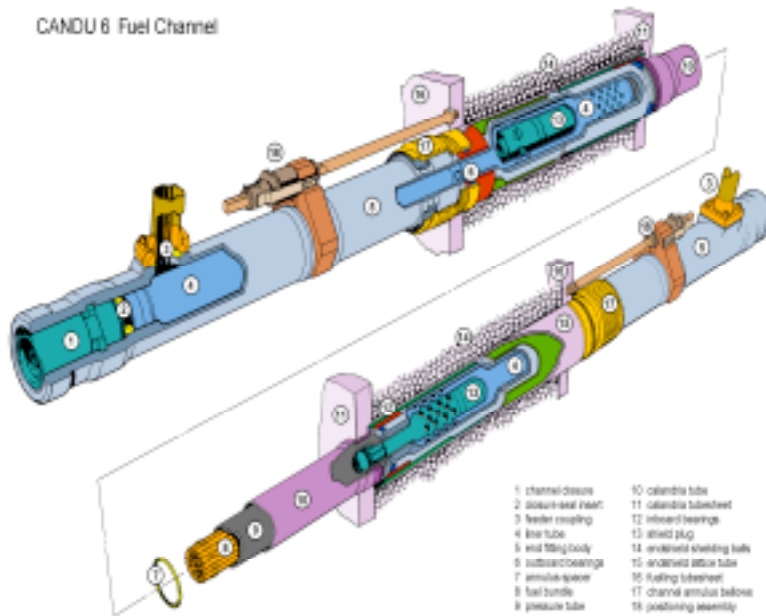

The pressure tube and end fittings are manufactured to the requirements of the ASME Boiler and Pressure Vessel Code, Section III, “Rules for Construction of Nuclear Power Plant Components”, Subsection NB, “Rules for Class 1 Components” and form part of the primary heat transport system. The pressure tube has an inside diameter of about 104 mm, a wall thickness of about 4 mm and a length of about 6.3 m. The dissimilar metals of

the pressure tube and end fittings are joined by means of a high integrity, roll-expanded joint that has been qualified for in-reactor use by an extensive program.

The Third Qinshan Nuclear Power Plant has a design life of 40 years at an average capacity of 85%. This is readily achieved, in part, because the design of the fuel channel permits their replacement. The pressure tubes have a design life of 25 years at an average capacity factor of 85%.

## Reactivity Control Units

### General

The reactivity control units form the in-core sensing and actuating portions of the reactor regulating system and the two reactor shutdown systems, shutdown system 1 and shutdown system 2. Since they are physically parts of the reactor assembly, they share many common bases for their mechanical design. The following sections describe these common aspects of the reactivity control units.

All reactivity control units perform one of three functions for their respective system(s):

1. Those which measure fission power levels,
2. Those which regulate power levels and,
3. Those which shutdown the reactor.

In CANDU reactors, emergency shutdown devices and systems are entirely independent of those used for reactor power regulation. Furthermore, two independent and diverse shutdown systems are provided, each of which has full shutdown capability independent of the other.

The following is a description of each reactivity control unit, its function and the system(s) in which it is installed. Further there is an initial description of three mechanical elements common to many of the reactivity control units, namely the reactivity mechanism deck, the thimbles and the guide tubes:

### Reactivity Mechanism Deck

The reactivity mechanism deck is a concrete-filled, carbon steel box structure, internally stiffened with webs that are located above the calandria in a space created in the top of the calandria vault. The concrete is not needed for strength, but for local radiation shielding during flasking. The steel structure incorporates the penetration inserts for the vertical reactivity control units. Each insert contains an accurately located bearing to support the reactivity control unit thimble. A heavy tread plate is supported above the

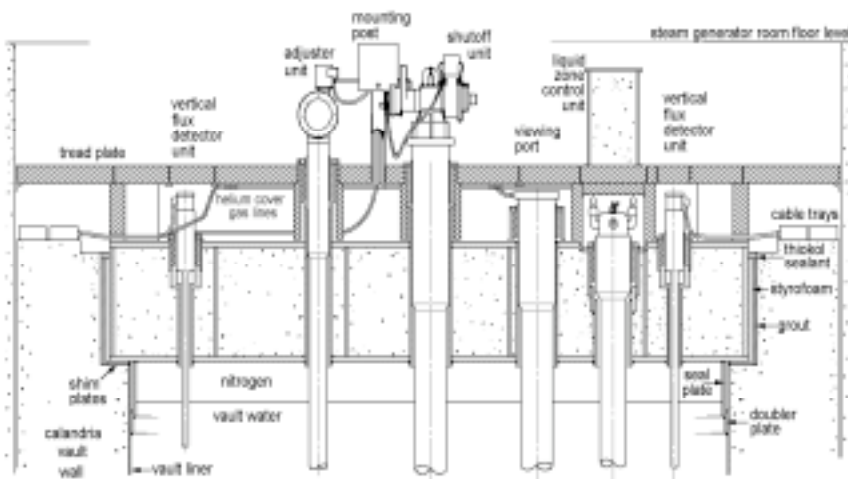

structure to provide a protected free space for cabling and services to the control units, while leaving an uncluttered walkway above for maintenance access. The tread plate also provides added local shielding during flasking operations to remove a device from the

reactor core.

The deck structure is secured in a seat in the top of the vault through a wide, flexible, seal strip to accommodate thermal expansion, yet be sufficiently stiff to behave as a rigid coupling under seismic conditions.

## Thimbles

The vertical thimbles extend from the top of the calandria up through the reactivity mechanism deck and are surrounded by the vault light water. They are welded in precise locations to the calandria shell nozzles and are vertically free to slide in bearings positioning them in the reactivity mechanism deck. Metal bellows are welded to the thimbles and deck penetrations to maintain a seal while permitting free vertical movement to accommodate differential thermal expansion between the thimbles and deck.

The horizontal thimbles extend from the shield wall through the vault wall to the calandria nozzles. Like their vertical counterparts, they are supported by bearings in the wall penetrations and are sealed by flexible metallic bellows. Each horizontal thimble also carries a second bellows, which connects to the liquid injection shutdown unit injection tube or horizontal flux detector assembly guide tube, acting both as a heavy water seal and a tensioner.

## Guide Tubes

Each guide tube assembly comprises a zircaloy tube that passes through the moderator in the core and a stainless steel out-of-core section. The out-of-core part is called a guide tube extension.

The guide tubes for the shutoff, mechanical control absorber and adjuster units have many large, close-pitched perforations along their length. This minimizes the amount of neutron absorbing material and also precludes voids in the moderator. The guide tubes are each seated at the top in precisely located conical seats in the bottom end fittings of the thimbles, which are welded to the nozzles at the top of the calandria shell. Their extensions are installed separately, and seat in the top fitting of the guide tubes.

The guide tube for the vertical flux detector unit is not perforated, but is vented to the moderator through small top and bottom holes. The guide tube of the horizontal flux detector units is not perforated or vented, but is a gas filled pressure-retaining tube. Both designs include a permanent mechanical joint between their two sections.

All vertical guide tubes are secured at their bottom ends by locators on the bottom of the calandria shell. The locators are adjustable laterally during initial installation, to permit

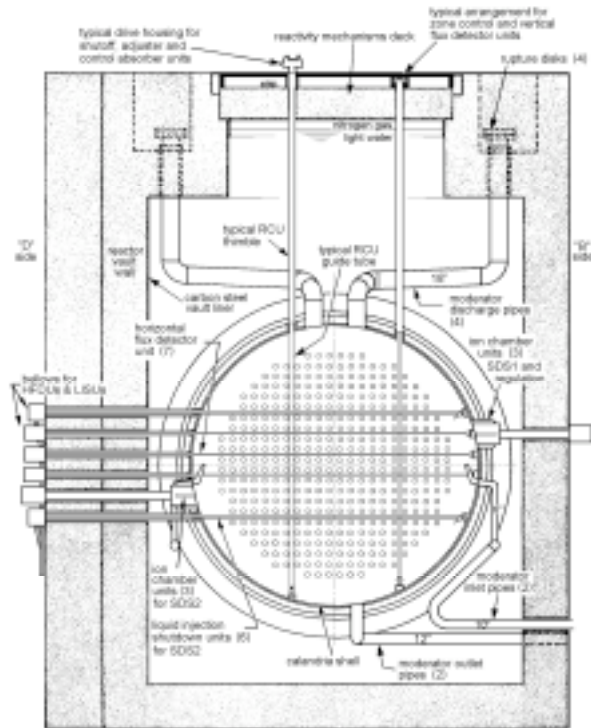



accurate alignment of the guide tubes' bottom ends. All guide tubes are tensioned flexibly to reduce the amplitude of vibrations induced either by water turbulence or possible earthquake, while also permitting differential thermal expansion between the guide tubes and the calandria. Vertical flux detector guide tubes are tensioned by a spring at the top of the extension. Horizontal flux detector guide tubes (and liquid injection shutdown unit nozzle tubes) are tensioned by metal bellows on the ends of their thimbles, outside the vault wall. Guide tubes for all other reactivity control units are tensioned by coil springs in the bottoms of the tubes, acting on the couplings, screwed into the locators.

## Shutoff Units

The 28 shutoff units comprise the absorber / actuator portion of shutdown system number 1. It is the primary method of quickly shutting down the reactor when certain parameters enter an unacceptable range. This shutdown system senses the requirement

for a reactor trip and de-energizes the direct current clutches to release the absorber element portion of the shutoff units, allowing them to drop between columns of fuel channels, into the moderator. Each shutdown rod is equipped with a spring that provides an initial acceleration.

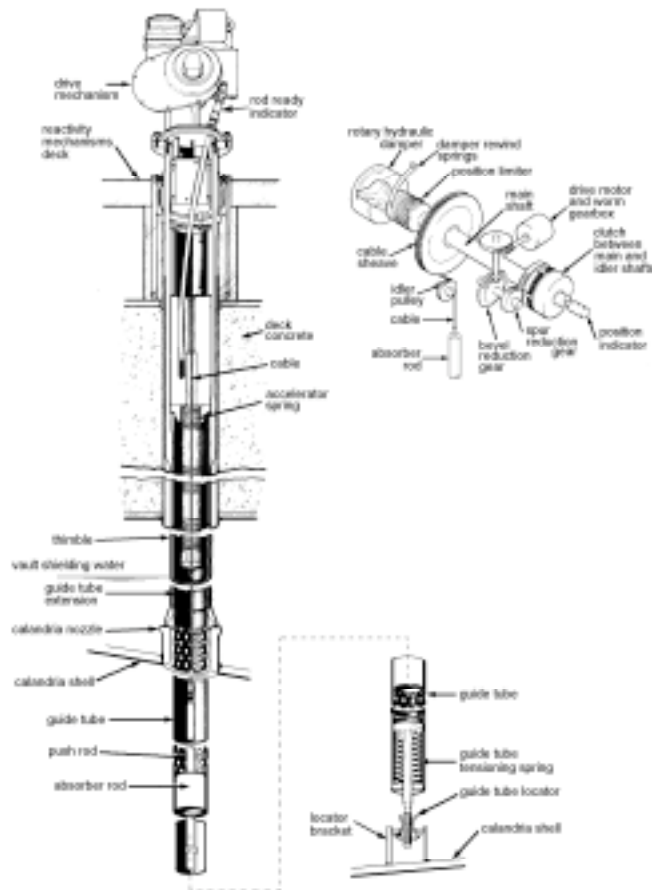

Each shutoff unit comprises a stainless steel-sheathed tubular cadmium shutoff rod, a vertical guide tube and guide tube extension, a drive mechanism and accelerator spring, a thimble, shield plugs and deck penetration components, and rod ready indicator. Each shutoff rod is suspended from a stainless steel wire rope wound onto the sheave of its drive mechanism.

The drive mechanism is an electric motor powered winch that includes an electro-magnetic clutch to couple the sheave shaft to its gear train. De-energization of the clutch permits the sheave to rotate freely, under the weight of the rod. The mechanism is bolted and sealed on the top of the thimble directly above the reactivity mechanism deck. A small acceleration is imparted to the rod

by the compressed accelerator spring over the first 0.6 m of travel. The fall of the rod is arrested at the end of its travel by a rotary hydraulic damper within the drive mechanism. When the clutch is energized by clearance of the trip signal, the motor raises the rod. The vertical position of the rod is measured by a rotary electrical potentiometer on its sheave shaft.

The sheave shaft is permanently coupled to the damper through the position limiter device. The damper vane stops against a fixed pad in the housing at each end of its travel, and thus provides the mechanical end of travel stops for the shaft rotation. When the rod is driven up or down, the motion is stopped before the end of mechanical travel is reached by the motor being shut off by the control system via the position sensing circuit run from the potentiometer output. A second position sensor, the "rod ready" indicator, directly monitors the presence of the rod in the up position, to verify it is "ready" for use. It comprises a set of magnetic switches mounted in a well in the shield plug, actuated by a permanent magnet mounted in the top of the shutoff rod.

### **Mechanical Control Absorber Units**

The four mechanical control units form part of the absorber / actuator component of the reactor regulating system. The mechanical control absorbers, mounted above the reactor, can be driven in or out of the core at variable speeds, or dropped by gravity into the core, between columns of fuel channels, by releasing a clutch. These absorbers are normally parked out of the core; they are driven in to supplement the negative reactivity from the light water zone control absorbers, or are dropped to effect a fast reduction in reactor power (stepback). When inserted, the mechanical control absorbers also help to prevent the reactor from going critical when the shutoff rods of shutdown system 1 are withdrawn, and are interlocked, in this inserted position, until the shutdown system number 1 is energized and available.

The mechanical control absorber units are essentially the same as the shutoff units, except that the shutoff unit accelerator spring and rod ready indicator are not incorporated, and the control absorber rod is provided with an orifice to reduce the insertion velocity for a free drop insertion.

### **Adjusters**

A CANDU 6 reactor has 21 vertically mounted adjuster rods, that are normally fully inserted between columns of fuel channels as part of the reactor regulating system, and are used for flux shaping. Removal of adjusters from the core provides positive reactivity to compensate for xenon buildup following large power reductions, or in the event that the on-power refuelling system is temporarily unavailable. The adjusters are capable of being

driven in and out of the reactor core at variable speed to provide reactivity control. The adjusters are normally driven in banks, the largest bank containing five rods. Adjuster rods are usually fabricated from stainless steel. In some CANDU plants the adjuster rods contain cobalt, and are used to produce cobalt 60 for medical and industrial purposes.

Each adjuster unit comprises an adjuster rod, a vertical guide tube and guide tube extension, thimble and shield plugs, and a drive mechanism. The adjuster rod consists of a thin-walled stainless steel tube with a central stainless steel shim rod. The absorber element and its shim center rod are of stepped thicknesses along their lengths to provide required neutron absorption characteristics. Each rod is suspended by a stainless steel wire rope from its mechanism. The vertical location of the rod is indicated by a potentiometer coupled to the drive mechanism sheave shaft.

The adjuster drive mechanism is a permanently coupled, electric motor powered, geared winch. The high reduction ratio in the gearing makes it self-locking. The sheave is enclosed in a pressure vessel housing whose interior is open to the moderator cover gas in the thimble. Its shaft passes through a carbon / ceramic face seal to the non-pressurized gear case. The drive housing is bolted and sealed to the thimble top.

The movement of the rods as they are raised or lowered is guided within perforated guide tubes within the calandria, and in plain guide tube extensions above.

### **Liquid Injection Shutdown Units**

The liquid injection shutdown nozzles are the in-core components of shutdown system number 2. This is an alternate method of quickly shutting down the reactor by the rapid injection of poison (concentrated gadolinium nitrate solution) into the moderator through perforated horizontal zircaloy tubes that span the calandria between rows of fuel channels. There are six poison injection nozzles in a CANDU 6 reactor. Shutdown system number 2 senses the requirement for a reactor shutdown and opens fast-acting valves located in the line between a high-pressure helium tank and the poison tanks. The released helium expels the poison solution from the tanks by acting on the polyurethane poison injection tank balls floating on the surface of the poison solution. Thus, the poison solution is forced through the injection nozzles and into the moderator. The injection ceases and the calandria is isolated from the helium when the balls reach seats in the bottom of the poison injection tanks.

Each liquid injection shutdown unit comprises an in-core injection nozzle tube, an injection tube, a thimble and a calandria vault wall penetration assembly. The injection nozzles screw into the stainless steel injection tubes at their inlet ends and bayonet into locators on the opposite side of the calandria. Each nozzle is perforated by rows of small nozzle holes spaced and oriented to optimize poison dispersal in the moderator.



## **Ion Chamber System**

There are a total of six ion chamber housings in a CANDU 6 reactor. Each housing contains three cavities which can accommodate an ion chamber unit, a test shutter cylinder or start-up instrumentation. Three ion chambers are employed in the reactor regulating system, for measuring neutron flux. These ion chambers are located in housings at one side of the core. In addition to one ion chamber for the reactor regulating system, each housing also contains an ion chamber and shutter for shutdown system number 1. Three similar ion chambers, mounted on the other side of the core, provide inputs to shutdown system number 2.

Each ion chamber unit consists of the ion chamber housing, access tubes and vault wall penetration assembly, shield plugs, ion chamber instruments and cables, and the shutter assembly and its air connections. Brackets welded to the outside of the calandria shell are also parts of these units.

Ion chamber housings do not penetrate inside the calandria, and their interior is vented to the reactor-building atmosphere outside the vault wall. The housings and the access tubes penetrating the vault wall are uniquely designed as low-pressure vessels with vault water on their exterior surface. The housing is filled with lead surrounding the instrument cavities, to absorb gamma flux and make the instruments sensitive only to neutrons.

The access tubes pass through a penetration assembly in the vault side-wall. These permit direct manual installation or removal of the instruments, shutter assembly, shield plugs and electrical and air connections. They are enclosed in the vault wall penetration by a protective sleeve. A bellows maintains a light water seal while being flexible to allow for relative movement between the calandria and the vault.

The shutter assembly consists of a boron cylinder mounted on a push rod which extends back through the inner shield plug segment, on bearings, to the air cylinder which is buried in the outboard segment of the shield plug. An electric switch on the rod signals the stroking position of the shutter.

## **Self-powered In-core Flux Detectors**

The in-core flux detectors of the regulating system and of shutdown system number 1 are mounted vertically in the core, while those of shutdown system number 2 are mounted horizontally in the core.

Each flux detector unit consists of a flux detector assembly, a guide tube, a thimble, and penetration and seal components at either the reactivity mechanism deck or the vault wall.

The flux detector assembly comprises a factory sealed capsule tube containing a number of detector elements in individual well tubes, joined to the connector housing and enclosing individual connectors and shield plugs. It is filled and sealed with pure helium at moderate pressure to ensure that the detectors obtain the maximum protection against possible corrosion. The helium also provides thermal conduction of nuclear heat from the detectors to the cool guide tube.

The in-core portion of each flux detector assembly comprises a full-length capsule tube assembly, inserted into a guide tube. A cluster of twelve thin well tubes is inserted into the capsule tube. Eleven well tubes can be used to insert straight individually replaceable self-powered detector elements of varied lengths of lead wires to reach specified in-core positions; all assemblies have fewer than eleven detectors installed and vacant sites are filled with shield plugs.

Each detector element comprises a central emitter wire enclosed in a sealed, thin Inconel sheath tube. A ceramic insulator separates the two conductors. Different metals are used for emitters to provide the different response characteristics. Each element is about 0.7 m long and carries an integrally connected sheathed lead wire, terminated at an individual connector inside the connector housing.

The twelfth well tube normally carries a shield plug and is reserved for other possible uses.

### **Light Water Zone Control Assemblies**

Light water (H<sub>2</sub>O) is a neutron absorber (poison) in the heavy water cooled and moderated CANDU reactor. The liquid zone control system takes advantage of this fact to provide short-term global and spatial reactivity control and is another part of the reactor regulating system. The liquid zone control system in the reactor consists of six tubular, vertical, zone control units that span the core. Each zone control unit contains either two or three zone control compartments, providing a total of 14 zone control compartments in the reactor. The zone control units are located such that the 14 zone control compartments are distributed throughout the core, thereby dividing the core into 14 zones for the purposes of flux control. Flux (power) in each zone is controlled by the addition or removal of light water to / from the liquid zone control compartment in that zone. This is accomplished by controlling the level of light water in the liquid zone control compartment.

The zone control unit does not have a guide tube, as it is inserted directly through the thimble into the moderator.

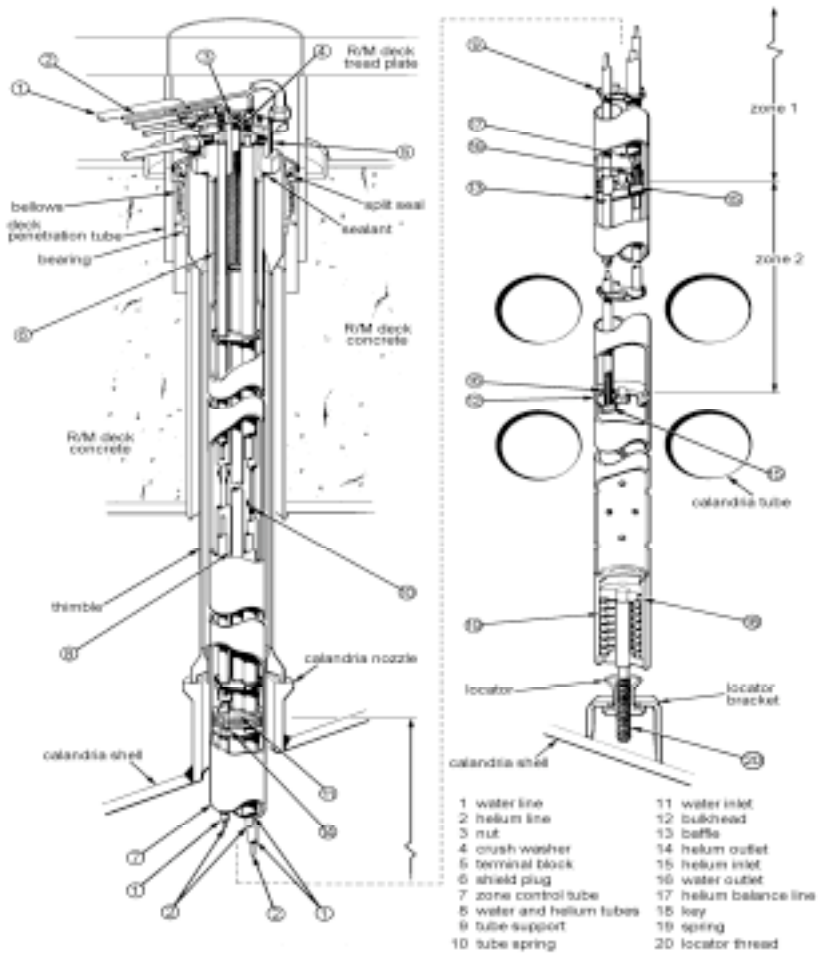

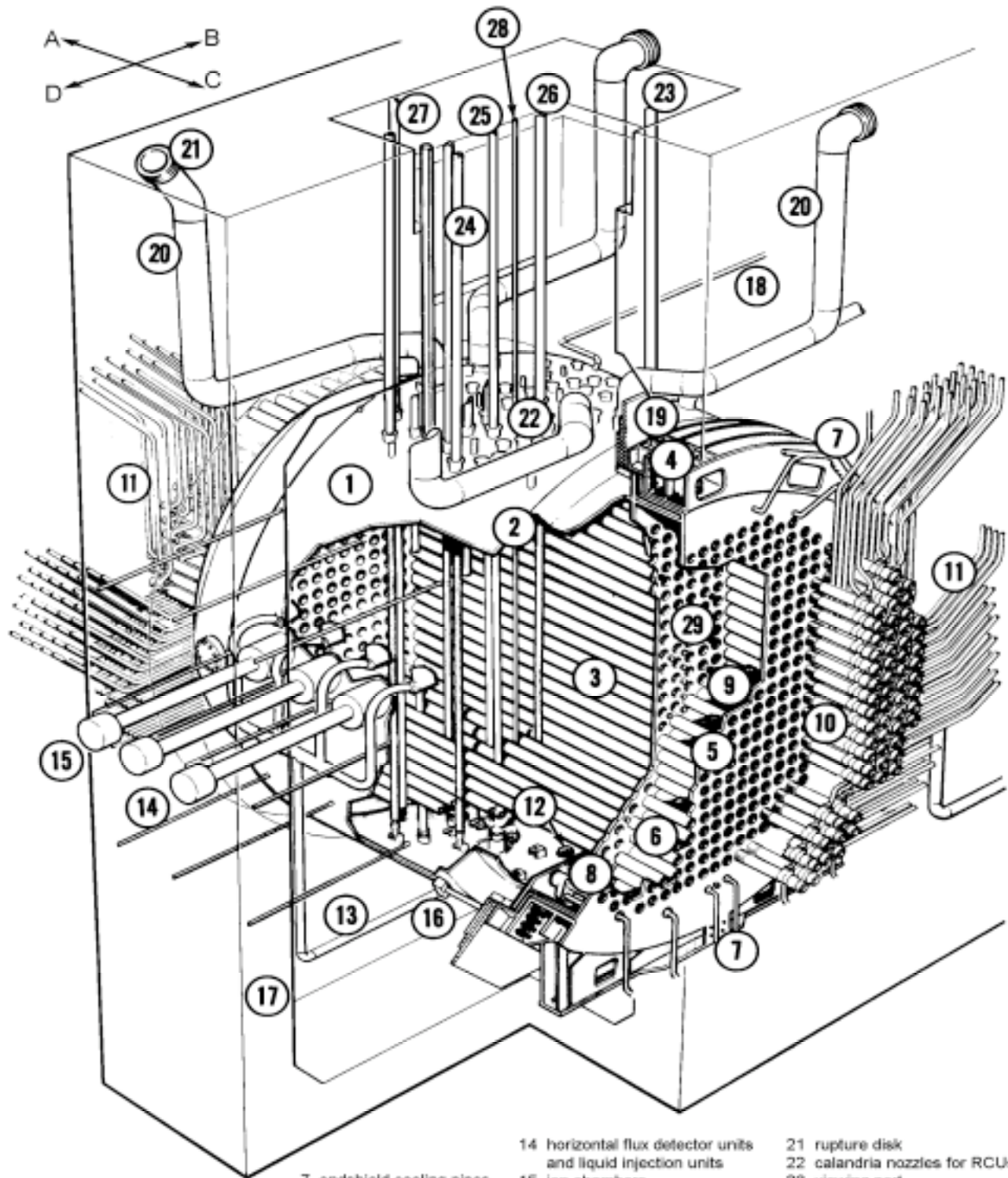

- 1 calandria
- 2 calandria shell
- 3 calandria tubes
- 4 endshield embedment ring
- 5 fuelling tubesheet
- 6 endshield lattice tube

- 7 endshield cooling pipes
- 8 inlet-outlet strainer
- 9 steel ball shielding
- 10 fuel channel end fittings
- 11 feeder pipes
- 12 moderator outlet
- 13 moderator inlet pipe

- 14 horizontal flux detector units and liquid injection units
- 15 ion chambers
- 16 earthquake restraints
- 17 reactor vault wall
- 18 pipe to moderator expansion head tank
- 19 curtain shielding slabs
- 20 moderator discharge pipes

- 21 rupture disk
- 22 calandria nozzles for RCUs
- 23 viewing port
- 24 shutoff unit
- 25 adjustor unit
- 26 control absorber unit
- 27 liquid zone control unit
- 28 vertical flux detector unit
- 29 calandria tubesheet

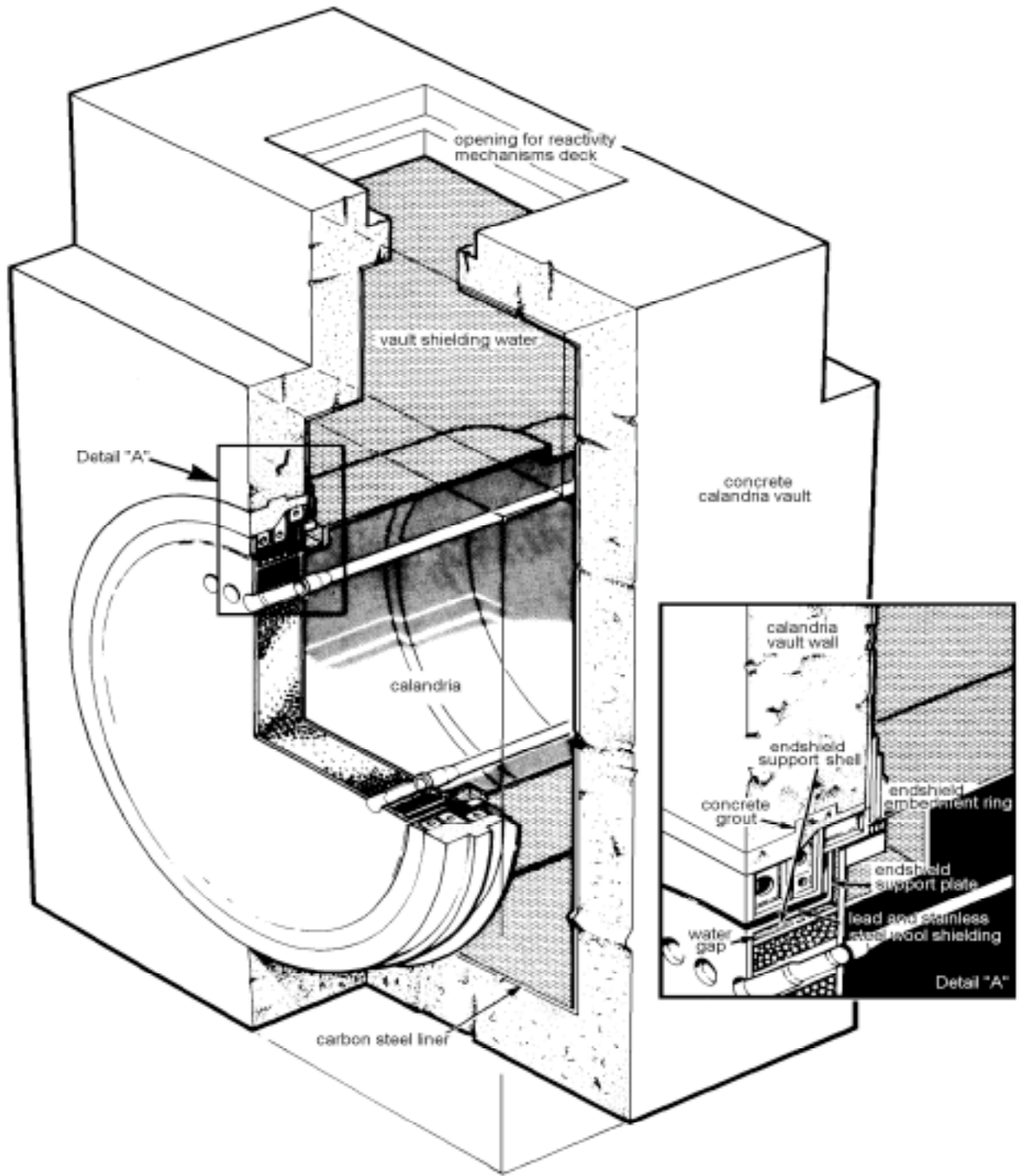

# CANDU 6 Fuel Channel

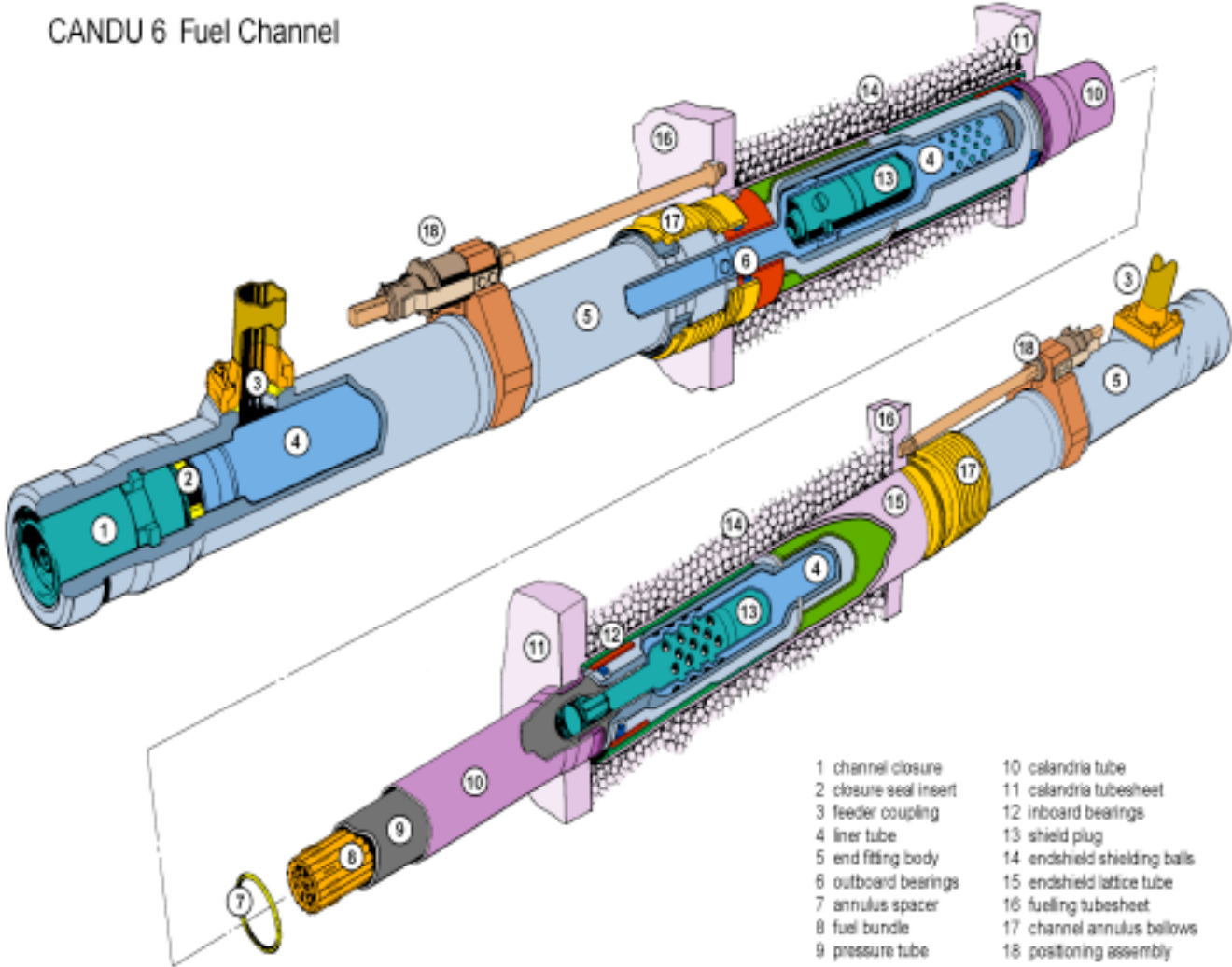

- 1 channel closure
- 2 closure seal insert
- 3 feeder coupling
- 4 liner tube
- 5 end fitting body
- 6 outboard bearings
- 7 annulus spacer
- 8 fuel bundle
- 9 pressure tube
- 10 calandria tube
- 11 calandria tubesheet
- 12 inboard bearings
- 13 shield plug
- 14 endshield shielding balls
- 15 endshield lattice tube
- 16 fuelling tubesheet
- 17 channel annulus bellows
- 18 positioning assembly



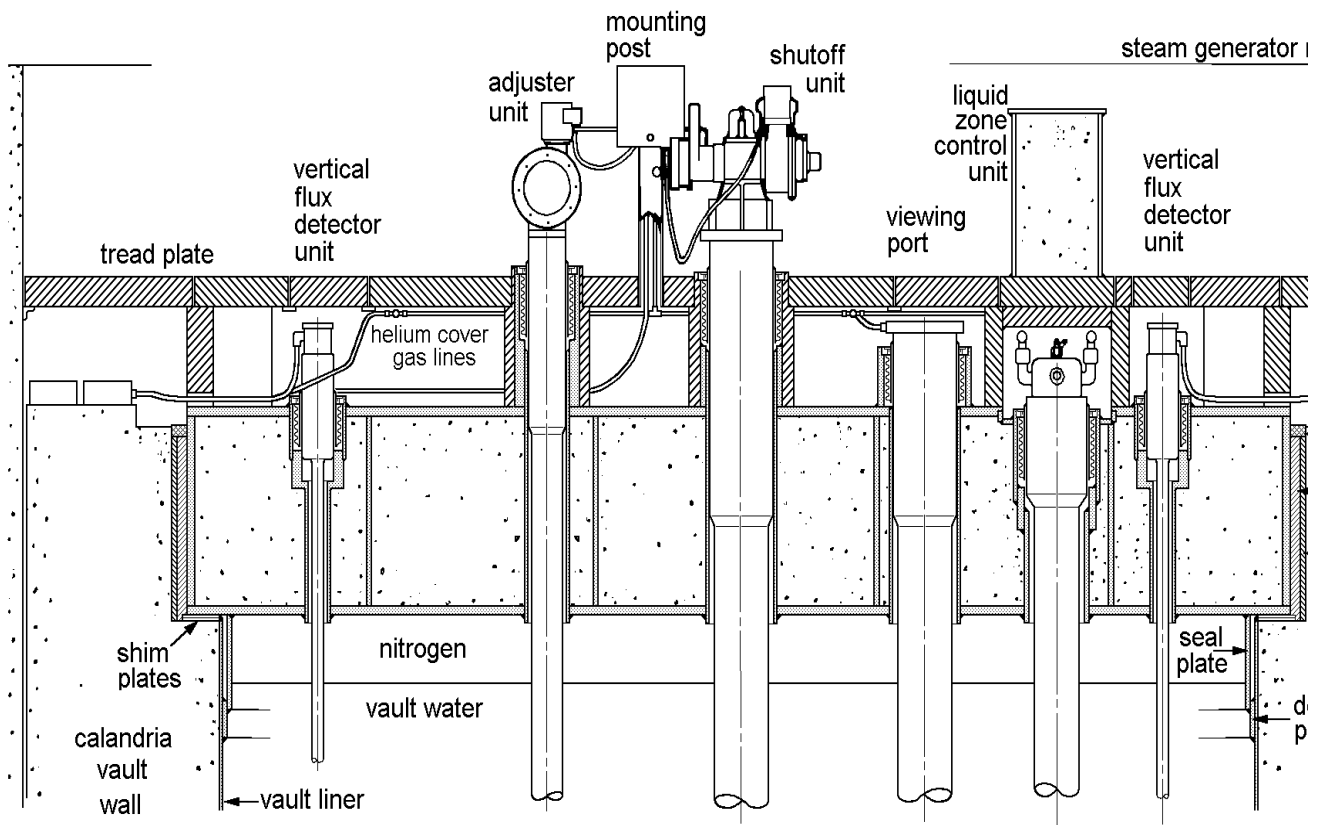

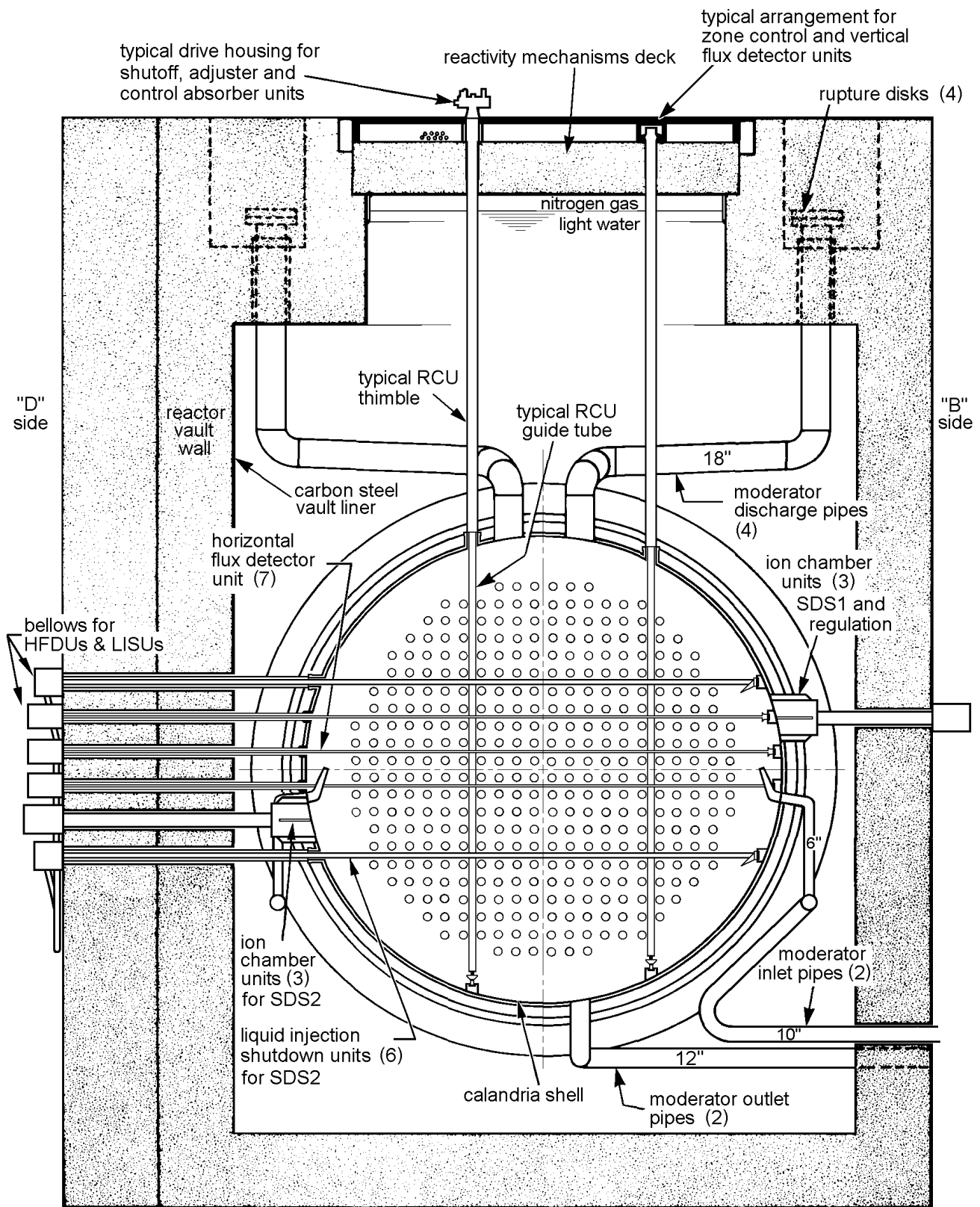

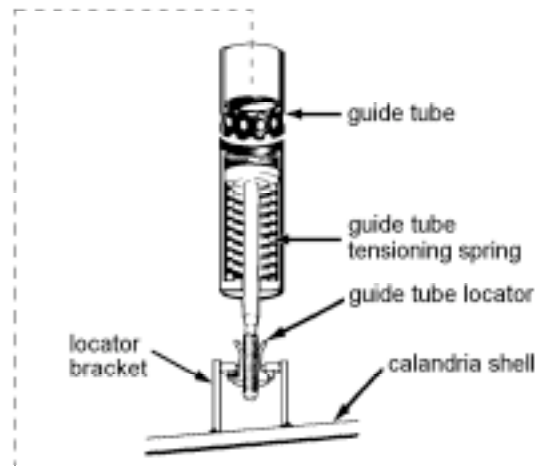
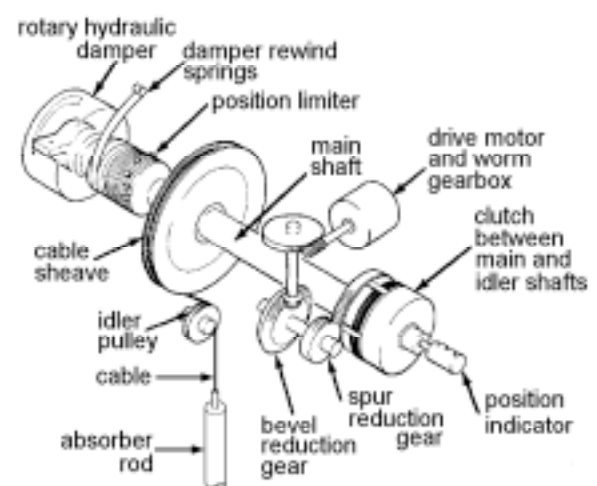
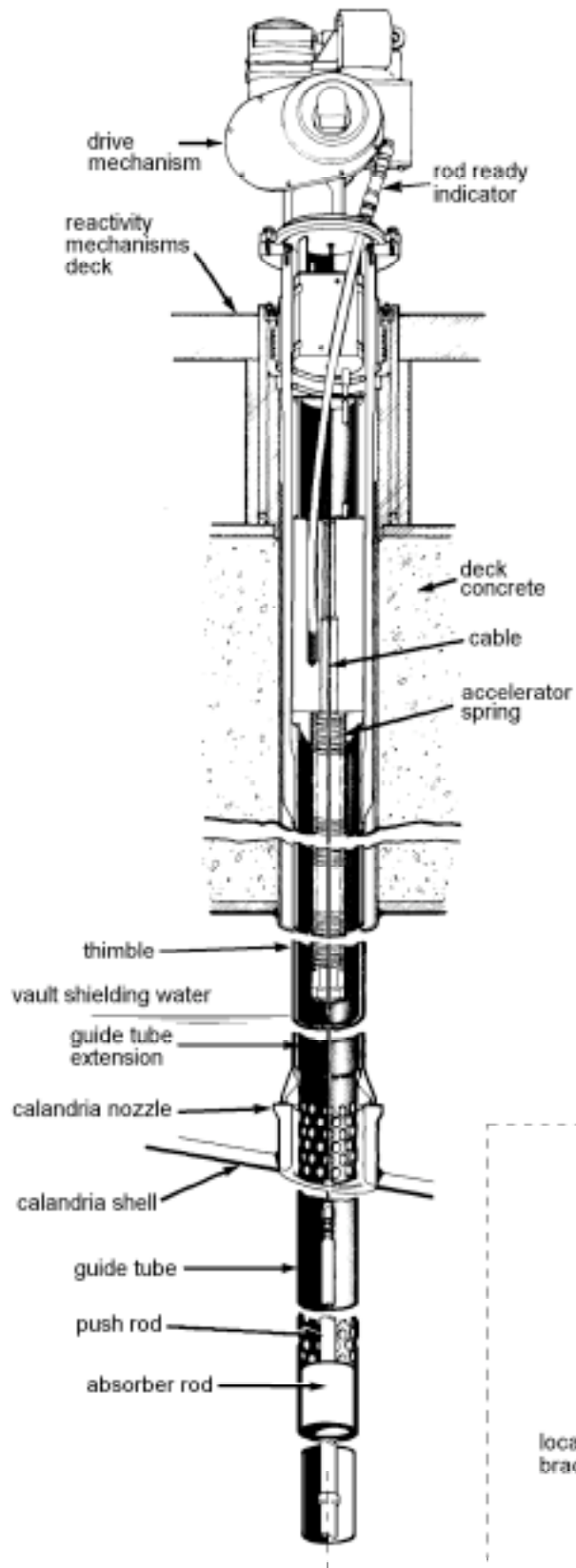

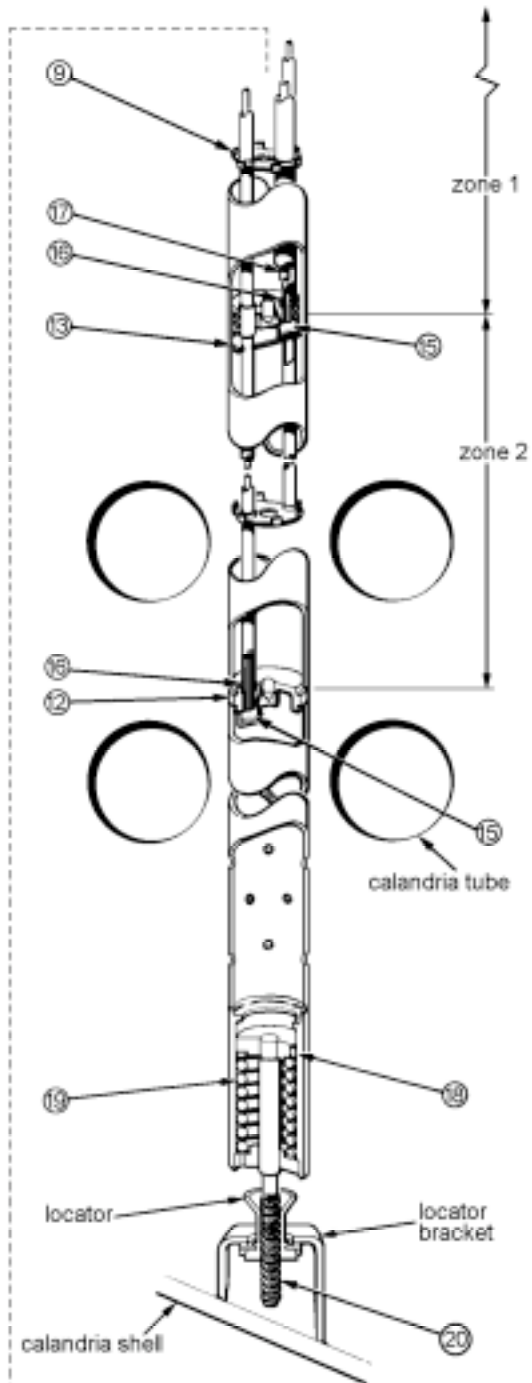
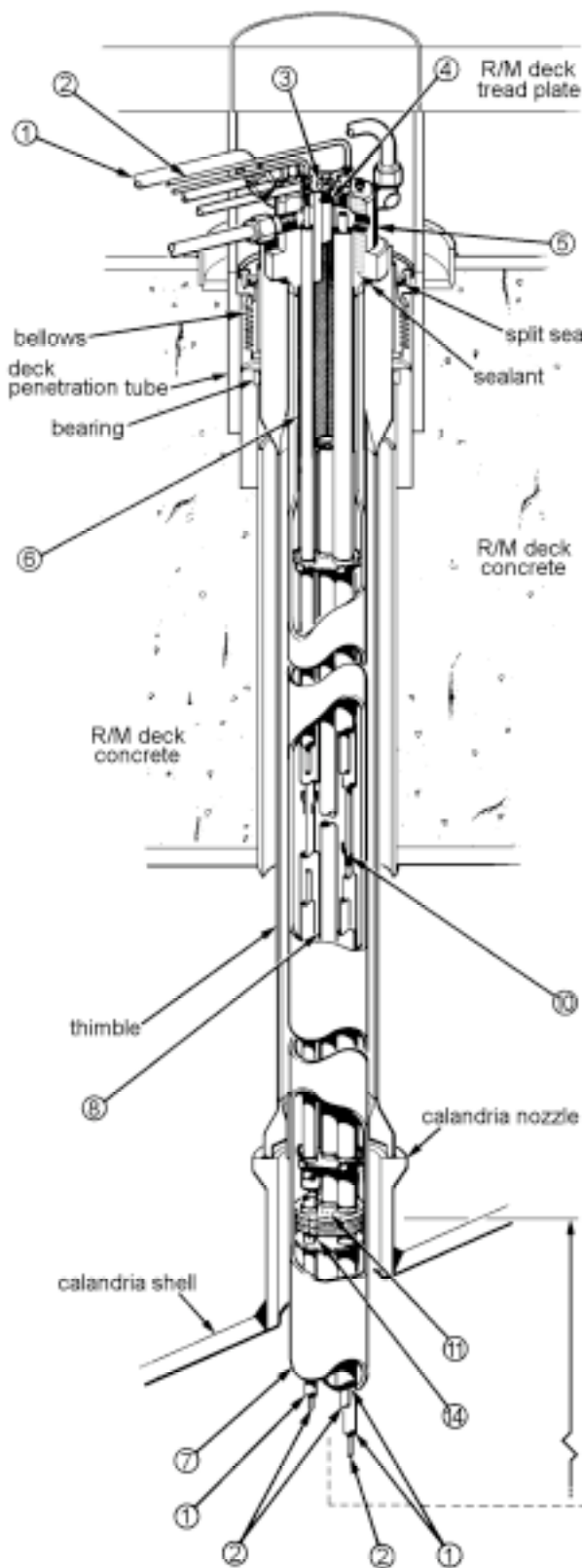

- |                          |                        |
|--------------------------|------------------------|
| 1 water line             | 11 water inlet         |
| 2 helium line            | 12 bulkhead            |
| 3 nut                    | 13 baffle              |
| 4 crush washer           | 14 helium outlet       |
| 5 terminal block         | 15 helium inlet        |
| 6 shield plug            | 16 water outlet        |
| 7 zone control tube      | 17 helium balance line |
| 8 water and helium tubes | 18 key                 |
| 9 tube support           | 19 spring              |
| 10 tube spring           | 20 locator thread      |